

BULL – AUTOMATIC HORIZONTAL STRAPPING MACHINE

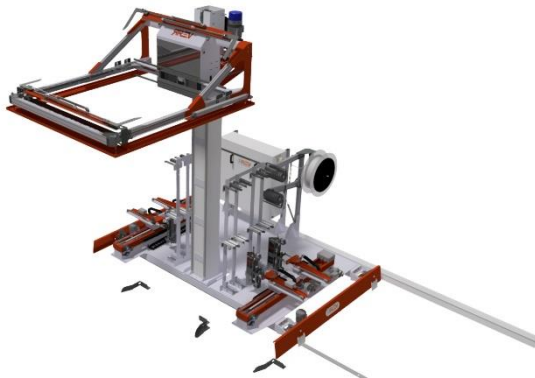

EXTREMELY FAST
LOW MAINTENANCE



WIDELY CONFIGURABLE
SAFE



- Machine for strapping **pallets of different sizes** by means of strap (in PP and PET) thermosealing. It can be installed on a fixed base or on a **mobile carriage**.
- Being equipped with a safety counterweight, in case of cave-in of the mechanical drive, the structure cannot crash.
- Strapping arch with safety bumper.
- Made of a solid central structure with head sliding on both axes, through linear guides in wear-resistant steel. This solution ensures a **minimum of maintenance** over time.
- **Strapping arch** with strap **anti-jamming** guides and pneumatic-control bobbin holder, for easing the unwinding.
- New optimised software with **self-learning functions**, for a high-level automation; the most common settings have been reduced to a minimum, for facilitating the operator.
- It works with pallets positioned longitudinally and transversally.
- **Easily programmable** with various recipes.
- **Tensioning strength variable** from recipe.

REV Packaging Solutions S.r.l.
Via F. Parri, 745, Cesena (FC), 47522, Italy
Tel. (+39) 0547 384435 - Fax (+39) 0547 635395 - info@revsrl.com
www.revsrl.com



BULL – AUTOMATIC HORIZONTAL STRAPPING MACHINE

- Crate compactor, for guaranteeing a stable pile and a **perfect positioning of the corners**, if any.
- Strap centring device, for **aligned and efficient strappings**.
- (Optional) **motorised corner applicator** with check of the position by means of encoder, for ensuring maximum precision for the positioning.
- **Double corner tank** (if the machine is equipped with the related applicator), usable for more formats too, with **pallet-height self-reading function**, for determining the type of corner to be applied.
- It is **the fastest strapping machine on the market**. If equipped with Turbo-Strap, Bull realises 9 strappings with corner application in just 1 minute and 45 seconds.
- Ideal for: pallets of different sizes and heights.

TECHNICAL FEATURES

- 4.3" colour touch-screen control panel
- New intuitive R-Touch graphic interface with production statistics
- Arch internal dimensions: 1480×1480 mm, for 1200×1200-mm pallets
- Maximum arch height: 2700 mm
- Strap dimensions: width: 12 mm; thickness: from 0.65 mm to 0.80 mm
- Minimum strapping height: 230 mm
- Strap-launch speed adjustable by means of inverter, for straps particularly difficult to work
- Production: according to the type of programme set

OPTIONS

- Motorised multiformat corner applicator
- Mobile carriage with up to 4 stations
- Turbo-Strap (+30% speed)
- Extra-Force, for increasing the strapping tensioning
- Safety barriers with photosensors
- Shim kit for pallet lines raised from the ground
- Different mounting configurations, according to the plant
- Different systems for barrier rearm and machine start
- Easy Remote teleassistance
- Integration into SCADA systems
- 4.0 interconnection

COMPLEMENTARY PRODUCTS

- Pallet handling systems
- Palletisers (Falcon)